

Magna Kit - M

(EL400 DRO and S1/S2 Scales)



DRO PROS

Scale Dimensions

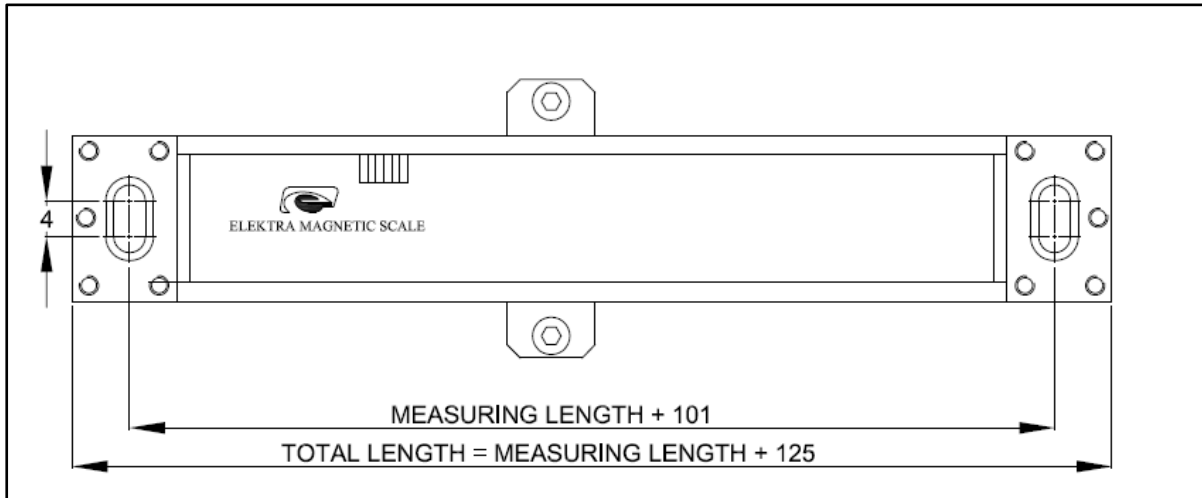

Figure 1

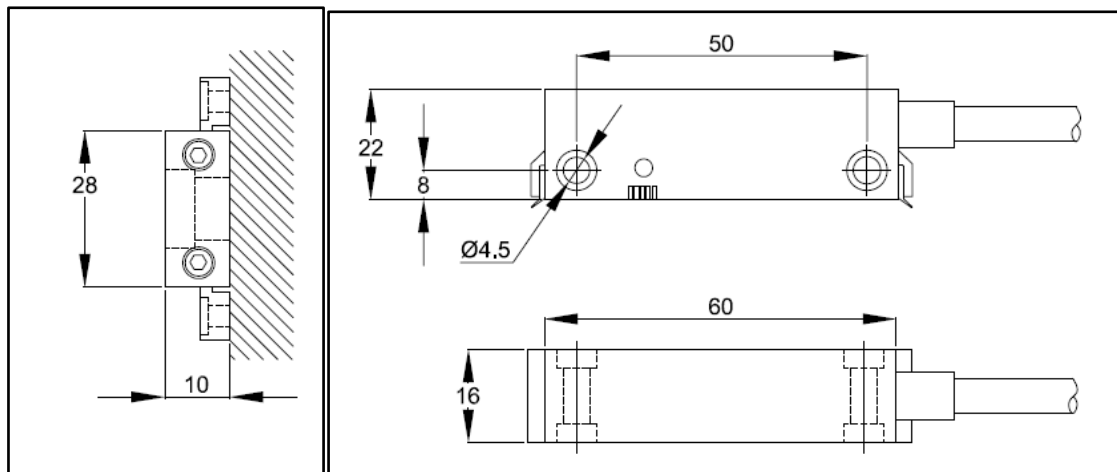

Figure 2

Figure 3

Mounting tolerances

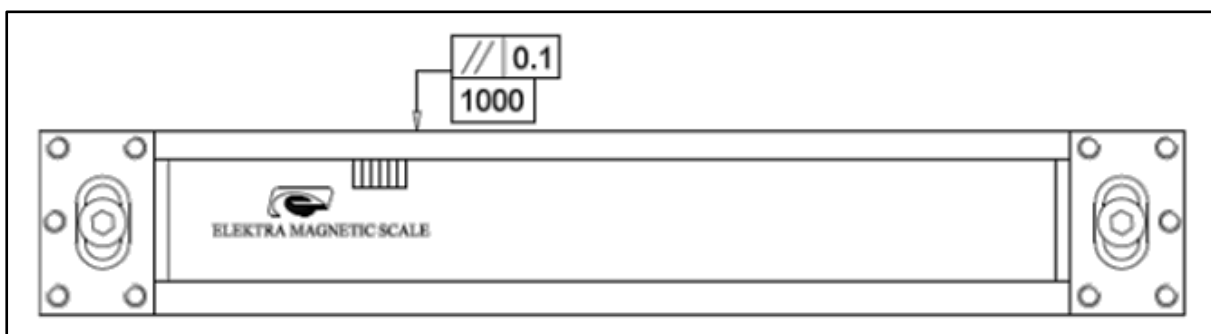

Figure 4

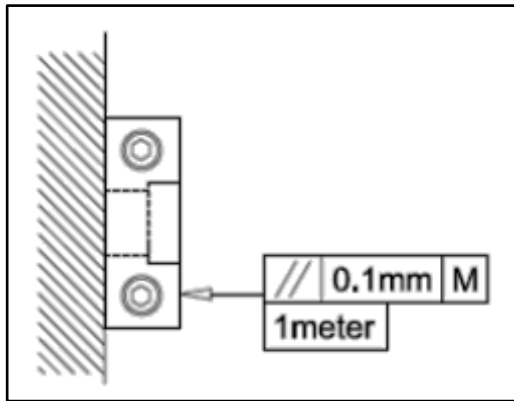

Figure 5

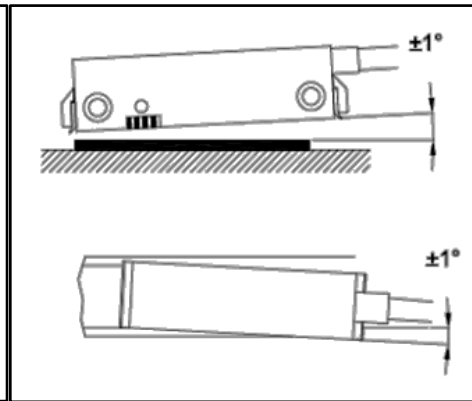

Figure 6

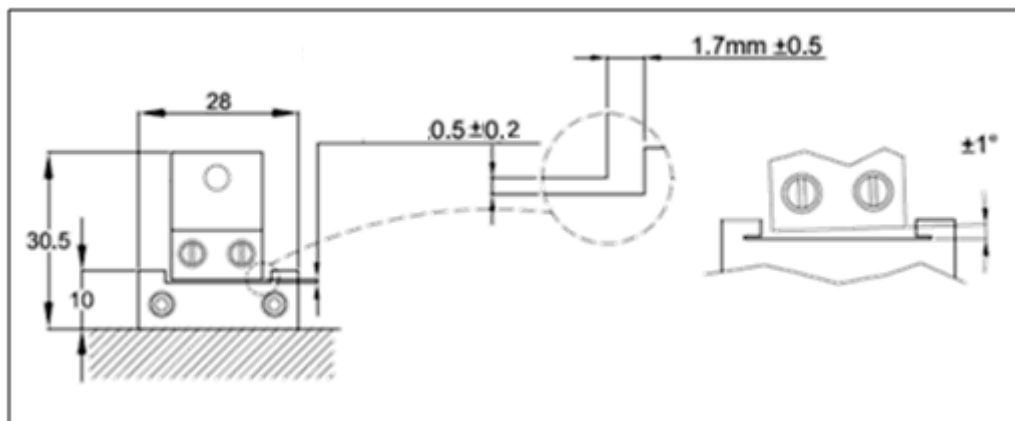

Figure 7

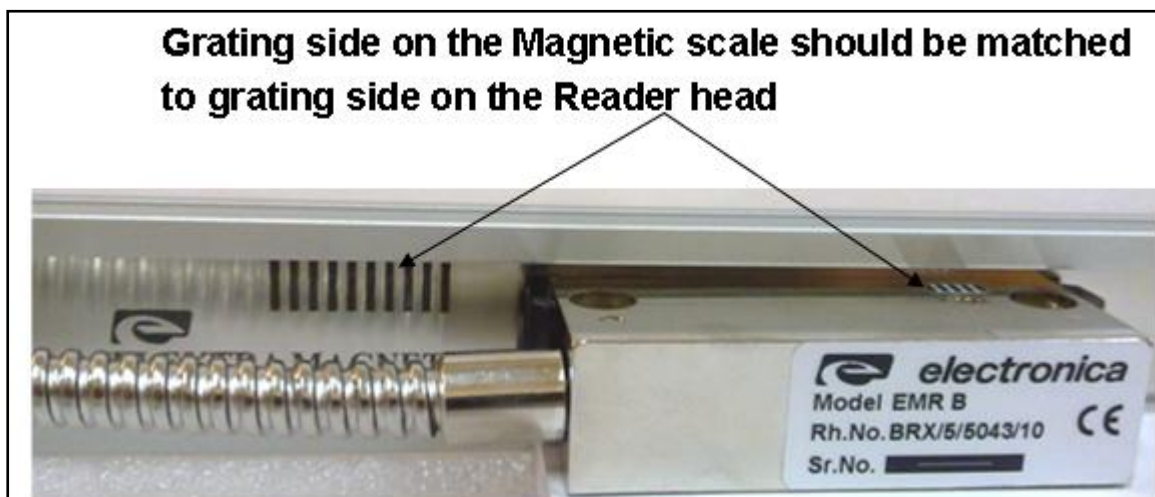

Figure 8

X Axis Scale mounting instructions

1. Clean the back side of the saddle of machine where the X axis scale is to be fitted.
2. The best location for mounting the scale is as near to the centre line of the slide, or as close to the guide-ways of the machine as possible.
3. Mount the scale as per the tolerances given above. The mounting should be as shown in the figure below. The end bracket of the scale has facility for plain adjustment which will be helpful in mounting for keeping the tolerances.

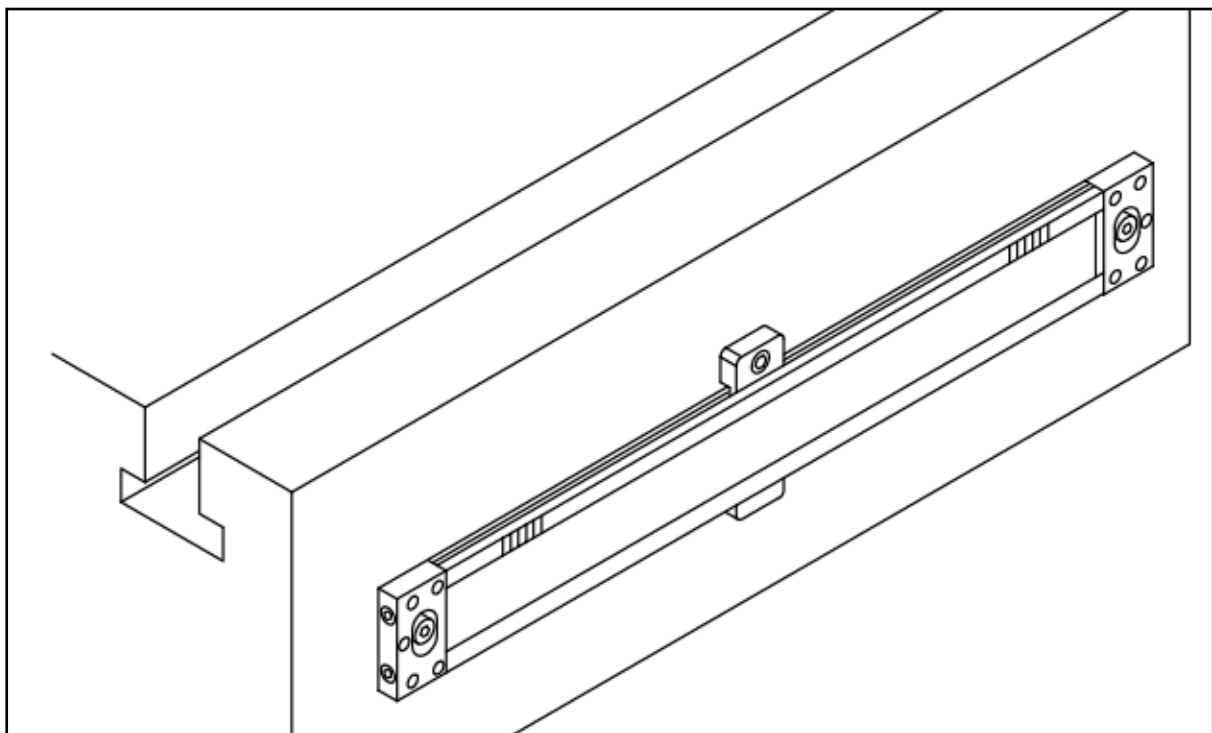

Figure 9

4. The grating symbol on the scale should be matched to the grating symbol on the reader head. Refer Figure 8.
5. Mount the middle support clamp provided with the scale. The scale should be supported by the middle support after every 500mm.
6. Mount the reader head as per the tolerances given above. The mounting should be as shown in the figure below.

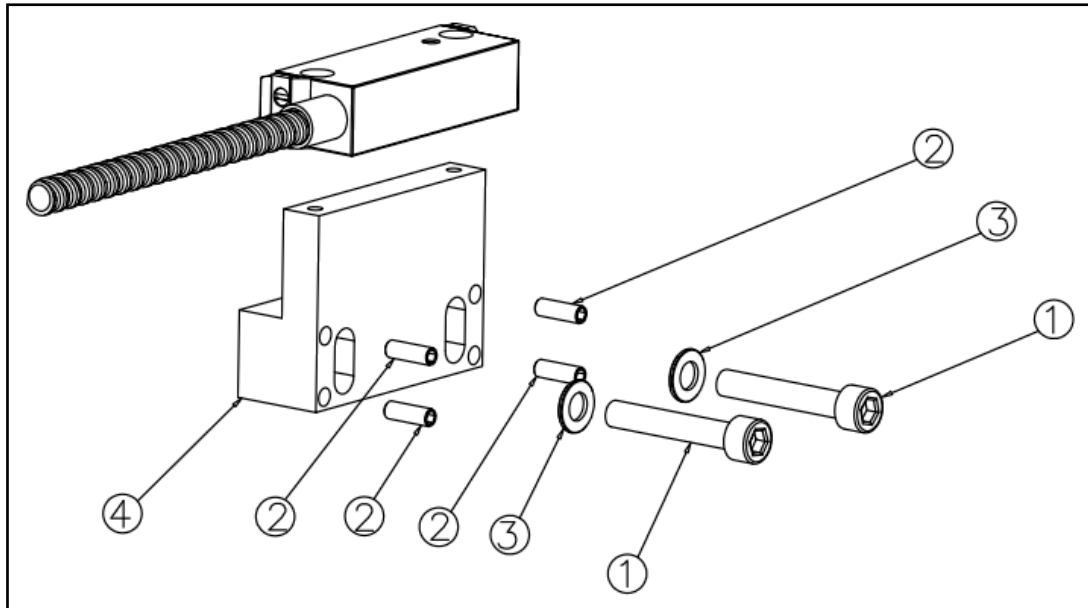

Figure 10

7. Move the slide over the full machine travel carefully to make sure that full machine travel is obtained. Do not over travel as it may damage the scale.
8. Mount the scale cover using the M4 X 10mm Slotted head (Cheese head) screws supplied with the scale. The cover is directly mounted on the scale end brackets.
9. Clamp the cables with the cable ties provided so they do not come in between the machine moving parts. The bending radius of the cable should not be less than 60mm. Refer routing instructions given in the Scale manual.

Y Axis Scale mounting instructions

1. Clean the back side of the saddle of machine where the X axis scale is to be fitted.
2. The best location for mounting the scale is as near to the centre line of the slide, or as close to the guide-ways of the machine as possible.
3. Mount the scale as per the tolerances given above. The mounting should be as shown in the figure below. The end bracket of the scale has facility for plain adjustment which will be helpful in mounting for keeping the tolerances.

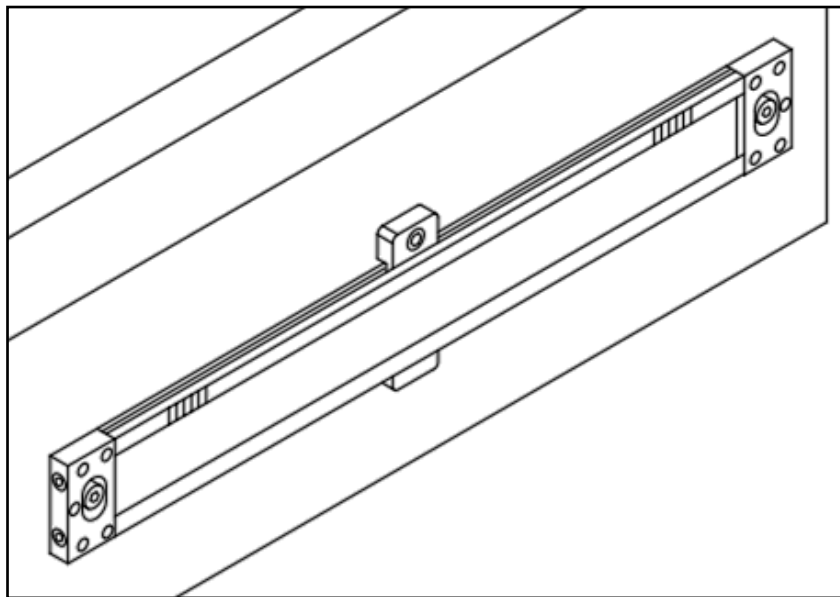

Figure 11

4. The grating symbol on the scale should be matched to the grating symbol on the reader head. Refer Figure 8.
5. Mount the middle support clamp provided with the scale. The scale should be supported by the middle support after every 500mm.
6. Mount the reader head as per the tolerances given above. The mounting should be as shown in the figure below.

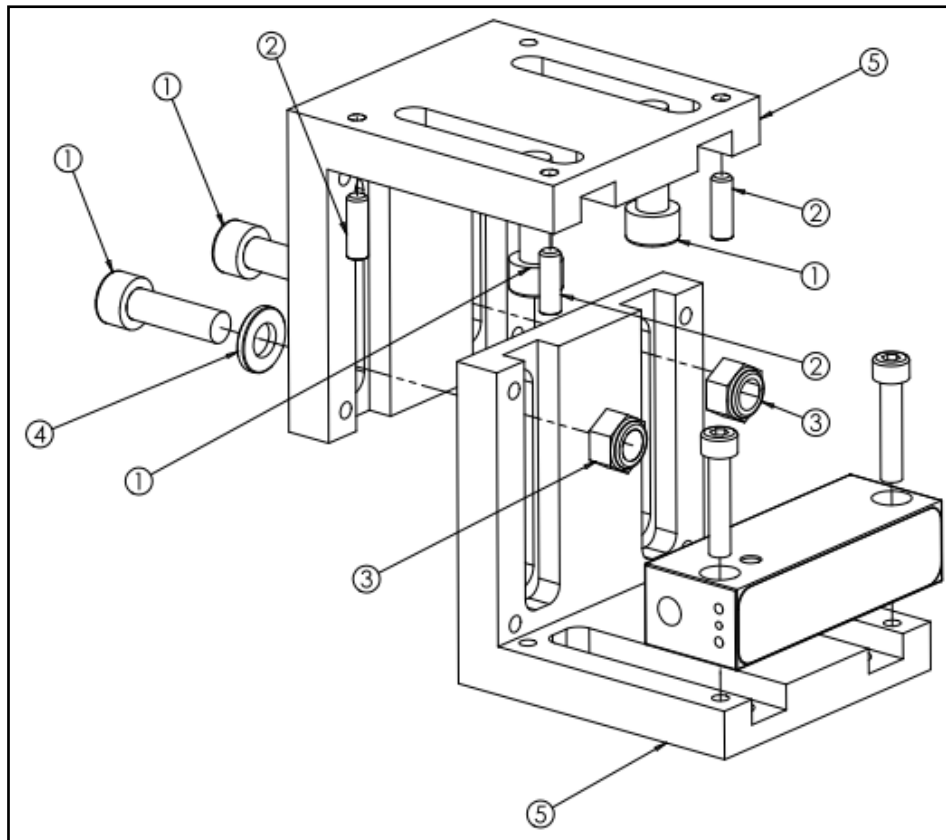

Figure 12

7. Move the slide over the full machine travel carefully to make sure that full machine travel is obtained. Do not over travel as it may damage the scale.
8. Mount the scale cover using the M4 X 10mm Slotted head (Cheese head) screws supplied with the scale.
9. Clamp the cables with the cable ties provided so they do not come in between the machine moving parts. The bending radius of the cable should not be less than 60mm. Refer routing instructions given in the Scale manual.

X Axis Hardware details

Scale:

Description	Quantity
Plain (Flat) Washer M4	2
Allen (Hex) Screw M4 X 16mm	2
Allen (Hex) Screw M4 X 10mm	2
Middle support Clamp	2

Reader Head (Refer Figure 10):

Item No.	Description	Quantity
1	Allen (Hex) Screw M6 X 35mm	2
2	Grub Screw (Set Screw) M4 X 12mm	4
3	Plain (Flat) Washer M6	2
4	Simple RH Mounting Bracket	2
-	Allen (Hex) Screw M4 X 20mm	2
-	Shim 0.5mm thick	1
-	Cable Tie mount	2
-	'P' Clip for cable Routing	3
-	Slotted (Cheese) Head Screw M4 X 10mm	3
-	Plain (Flat) Washer M4	3

Y Axis Hardware details

Scale:

Description	Quantity
Plain (Flat) Washer M4	2
Allen (Hex) Screw M4 X 16mm	2
Allen (Hex) Screw M4 X 10mm	2
Middle support Clamp	2

Reader Head (Refer Figure 12):

Item No.	Description	Quantity
1	Allen (Hex) Screw M6 X 20mm	4
2	Grub Screw (Set Screw) M4 X 12mm	4
3	Nylock Nut M6	2
4	Plain (Flat) Washer M6	2
5	'L' Type bracket for RH (Universal)	2
-	Allen (Hex) Screw M4 X 20mm	2
-	Shim 0.5mm thick	1
-	Cable Tie mount	2
-	'P' Clip for cable Routing	3
-	Slotted (Cheese) Head Screw M4 X 10mm	3
-	Plain (Flat) Washer M4	3



Recommended Tools

5.2mm Drill
3.5mm Drill
Power Drill
Center Punch
Hammer
M6 Tap
M4 Tap
Tap Wrench
5mm Hex Key
3mm Hex Key
Screw Drivers
Dial Indicator with base
Adjustable spanner

Note:

1. Connect the Scale connectors to their respective connectors on the DRO and tighten the locking screw using a screw driver.
2. The hardware mentioned in the manual are all Metric standard.
3. Refer to the installation manual for the scale and DRO for specifications and additional information.
4. Refer to the calibration procedure in the DRO user manual for the system calibration.

DRO Installation

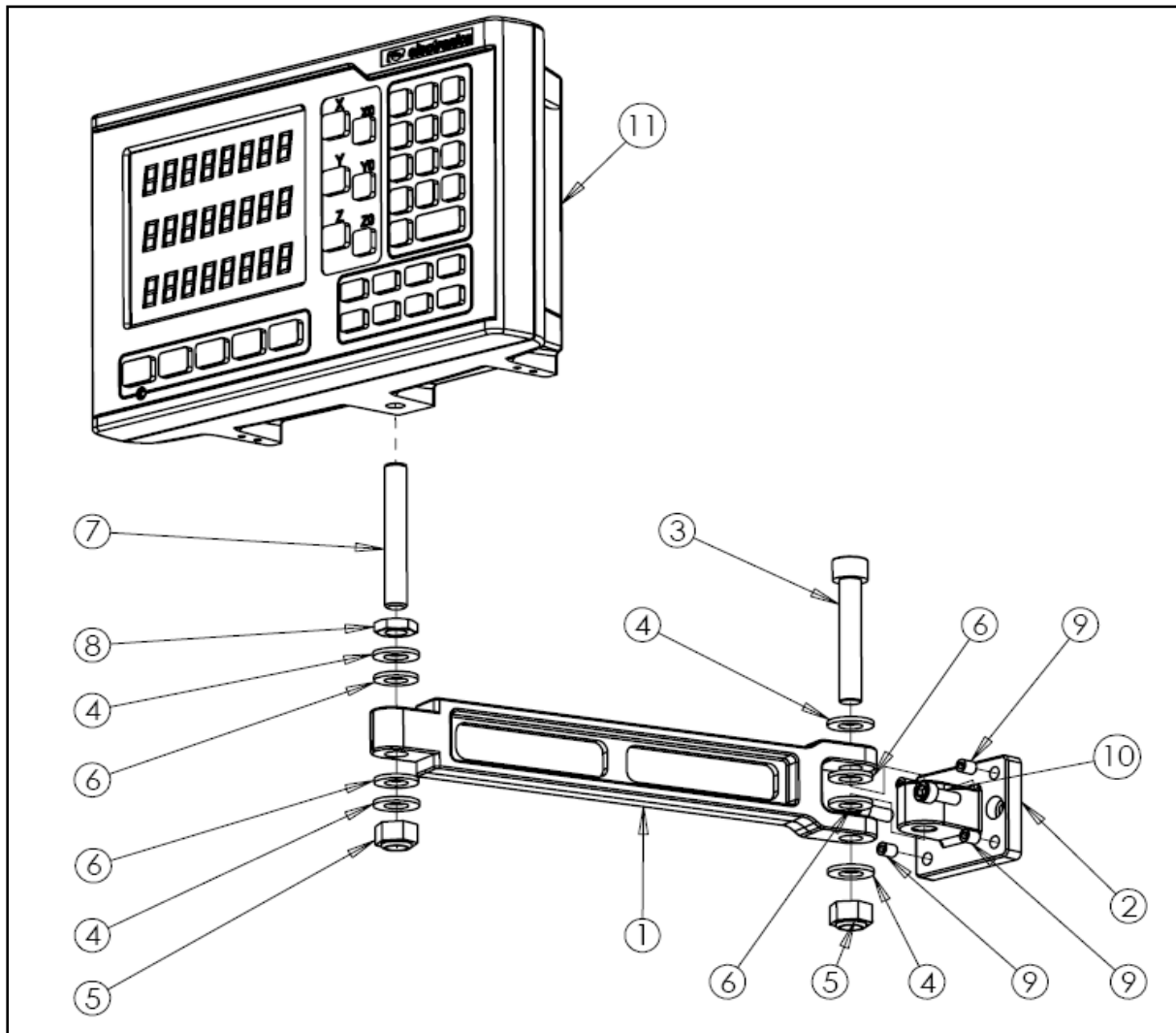

Figure 13

No.	Description	Qty.
1	Fork arm	1
2	Machine mounting Bracket	1
3	M10 X 60mm Allen head Screw	1
4	M10 punched washer	4
5	M10 Nylock nut	2
6	M10 Nylon spacer	4

No.	Description	Qty.
7	M10 X 75mm Stud	1
8	M10 Lock nut	1
9	M6 X 8mm Allen grub screw	4
10	M6 X 16mm Allen head screw	2
11	EL400 Series DRO	1